

HYDRAULIC CYLINDER SERIE S-300

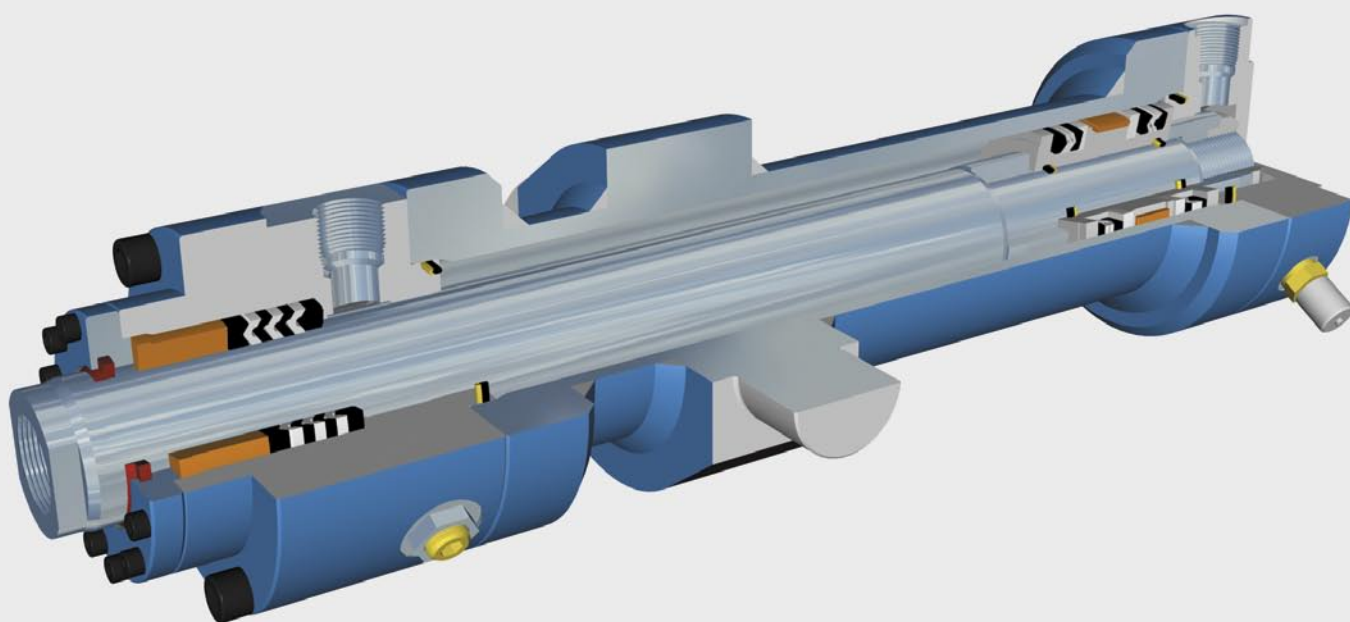

ARCOS STANDARD CYLINDER – S-300

The S-300 series was designed in close co-operation with the Swedish steel industry. Our engineers have optimised this design, and based it on the specific requirements demanded by the steel mills. Our 40 years of experience from manufacturing cylinders for heavy industry allows us to offer a heavy duty hydraulic cylinder which meets the high demands of availability and simplicity in maintenance for today and tomorrow.

S-300

- is a double-acting hydraulic cylinder designed for industrial use in heavy, continuous operations.
- is available, as standard, with two different types of seal, either with V-seals or U-seals. Cylinders with the latter type seal can also be used as servo cylinders (low friction seals).
- is designed according to ISO-Standard 6022, which makes it internationally exchangeable.
- is available in 13 diameters from Ø50 to 320 mm.
- is stocked, as standard, position cushioned or non-cushioned.
- can be fitted with 9 different means of mounting.
- is designed for 35 MPa continuous working pressure, intermittently to 55 MPa.
- is designed for high availability, long life span and easy maintenance.
- is designed so that there is no metallic contact between moving parts.
- is designed so that the user can easily switch between the two seal alternatives available as standard.

Basic Design S-300

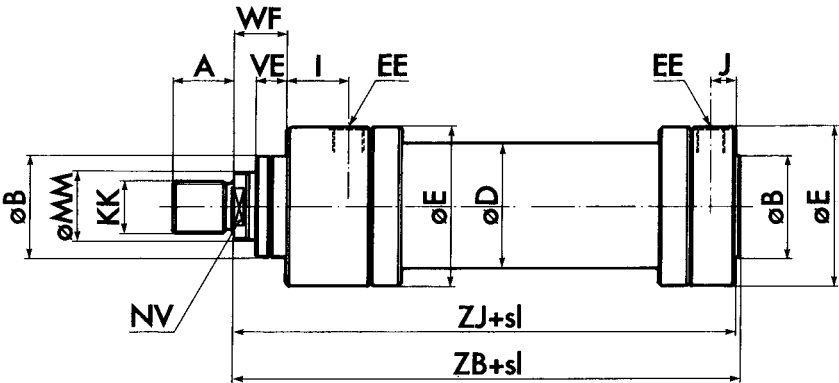

Cyl. dim.	Piston rod.	A	B	D	E	EE	I	J	KK	NV	VE	WF	ZB	ZJ
mm	mm	mm	mm	mm	mm	"	mm	mm	mm	mm	mm	mm	mm	mm
50	36	36	68	61	100	R 1/2"	46	17	M 27x2	30	29	47	244	240
63	45	45	85	76	125	R 3/4"	51	22	M 33x2	36	32	53	274	270
80	56	56	100	96	145	R 3/4"	65	21	M 42x2	41	36	60	305	300
100	70	63	115	121	165	R 1"	61	26	M 48x2	55	41	68	340	335
125	90	85	140	152	200	R 1 1/4"	66	30	M 64x3	75	45	76	396	390
160	110	95	160	193	250	R 1 1/2"	97	38	M 80x3	95	50	85	467	460
200	140	112	200	243	300	R 1 1/2"	114	50	M 100x3	115	61	101	550	540
250	180	125	250	318	380	R 1 1/2"	159	88	M 125x4	155	71	113	652	640
320	220	160	320	394	450	R 1 1/2"	170	106	M 160x4	200	88	136	764	750
140	100	85	150	167	220	R 1 1/4"	85	34	M 64x3	85	45	76	421	415
180	125	95	190	213	270	R 1 1/2"	117	38	M 80x3	110	50	85	497	490
220	160	112	230	273	340	R 1 1/2"	124	60	M 100x3	130	61	101	570	560
280	200	125	280	343	420	R 1 1/2"	169	88	M 125x4	180	71	113	662	650

S-300 MF3/MF4

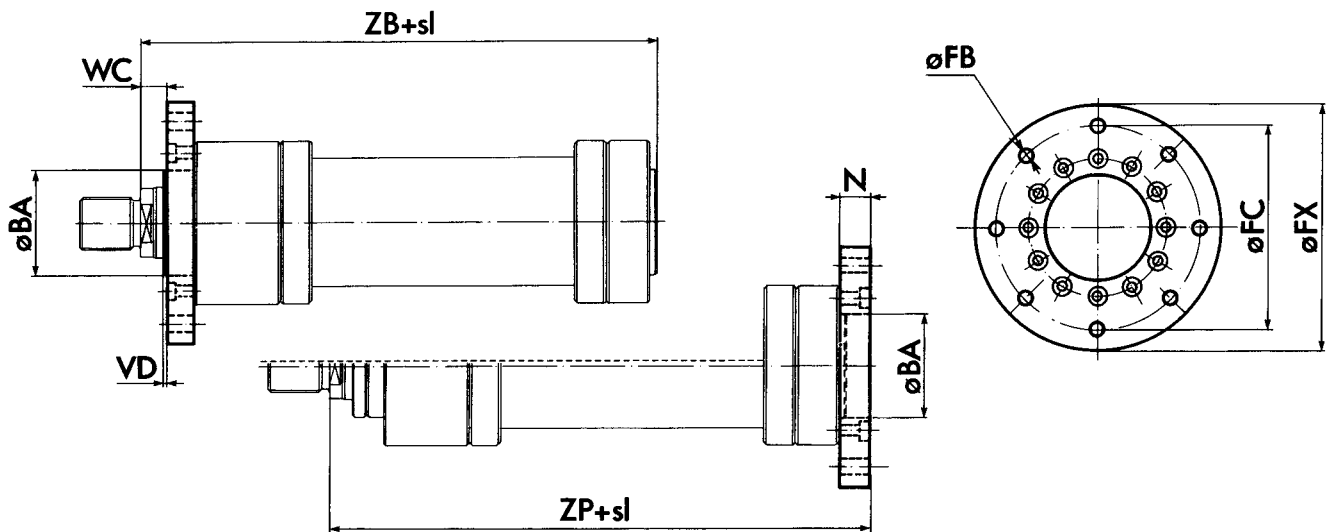

Cyl.dim.	Pistonrod.	BA	FB	FC	FX	N	VD	WC	ZB+	ZP+	Vikt
mm	mm	mm	mm	mm	mm	mm	mm	mm	mm	mm	kg
50	36	68	13,5	132	160	25	4	22	244	265	2,9
63	45	85	13,5	150	180	28	4	25	274	298	3,9
80	56	100	17,5	180	220	32	4	28	305	332	6,6
100	70	115	22	212	260	36	5	32	340	371	10,5
125	90	140	22	250	300	40	5	36	396	430	15,1
160	110	160	26	315	380	45	5	40	467	505	28,9
200	140	200	33	385	450	56	5	45	550	596	48,6
250	180	250	39	475	545	63	8	50	652	703	78,6
320	220	320	45	600	690	80	8	56	764	830	163,7
140	100	150	22	280	325	40	5	36	421	455	18,2
180	125	190	26	360	425	45	5	40	497	535	36,5
220	160	230	33	430	500	56	5	45	569	615	61,2
280	200	280	39	525	600	63	8	50	662	713	97,6

S-300 KG/MP6

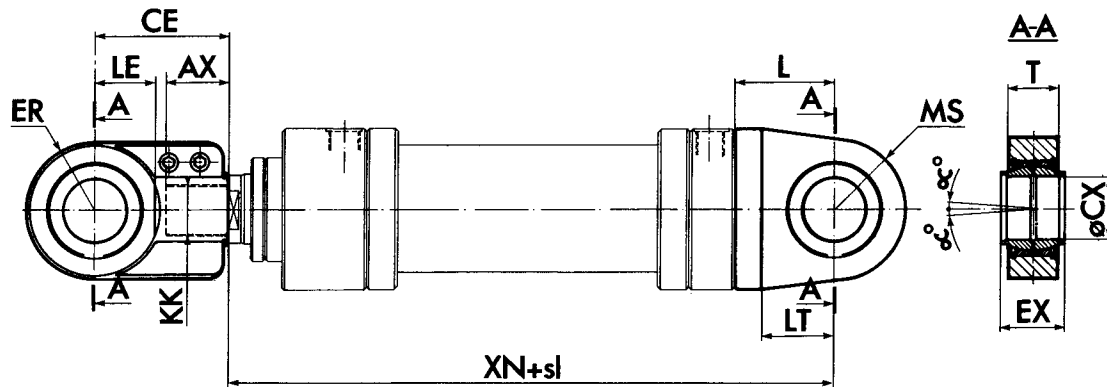

mm	mm	mm	mm	mm	mm	mm	mm	mm	mm	mm	mm	mm	mm	kg	kg
50	37	80	32	38	32	M 27x2	65	32	40	40	28	305	4	1,20	2,36
63	46	97	40	48	40	M 33x2	78	41	50	50	35	348	4	2,05	4,47
80	57	120	50	59	50	M 42x2	95	50	63	60	40	395	4	4,45	7,1
100	64	140	63	71	63	M 48x2	107	62	71	70	50	442	4	7,60	11,0
125	86	180	80	90	80	M 64x3	130	78	90	90	60	520	4	14,50	19,2
160	96	210	100	112	100	M 80x3	157	98	112	110	70	617	4	28,00	33,8
200	113	260	125	145	125	M 100x3	216	120	160	140	90	756	4	43,00	70,4
250	126	310	160	178	160	M 125x4	263	150	200	170	125	903	4	80,00	144,8
320	161	390	200	230	200	M 160x4	330	195	250	220	140	1080	4	165,0	245,8
140	86	180	80	90	80	M 64x3	140	78	100	100	70	555	4	14,50	26,4
180	96	210	100	112	100	M 80x3	160	98	115	120	80	650	4	28,00	43,4
220	113	260	125	145	125	M 100x3	215	120	160	150	100	775	4	43,00	89,4
280	126	310	160	178	160	M 125x4	265	150	200	190	125	915	4	80,00	169,0

S-300 MT4

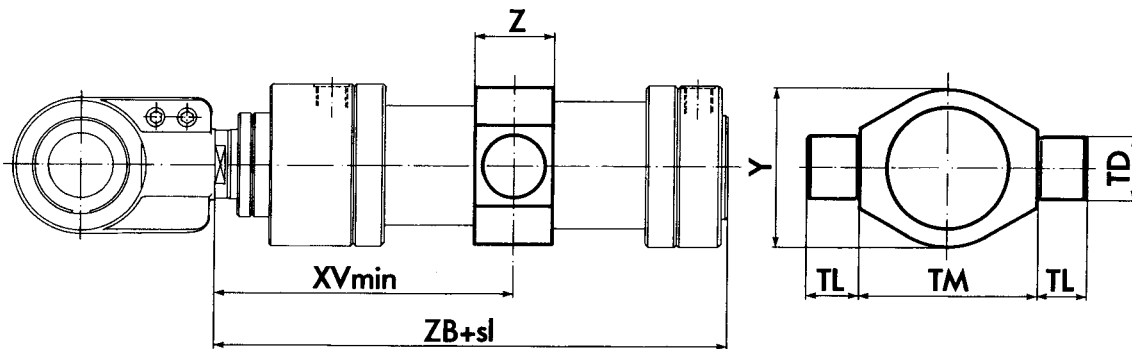

Cyl.dim.	TD f8	TL j16	TM h12	XV min	Y	Z	ZB max	Weight kg
mm	mm	mm	mm	mm	mm	mm	mm	kg
50	32	25	112	170	100	40	244	1,9
63	40	32	125	205	120	50	274	3,1
80	50	40	150	240	145	70	305	6,1
100	63	50	180	265	165	80	340	9,2
125	80	63	224	295	200	100	396	17,5
160	100	80	280	375	250	125	467	33,6
200	125	100	335	445	300	140	550	50,6
250	160	125	425	530	380	180	652	99,3
320	200	160	530	600	470	220	764	179,5
140	80	63	240	325	220	100	421	18,4
180	100	100	310	400	270	125	497	38,5
220	125	125	390	460	340	140	569	61,8
280160	160	150	485	550	420	180	662	112,3

Bearing Brackets

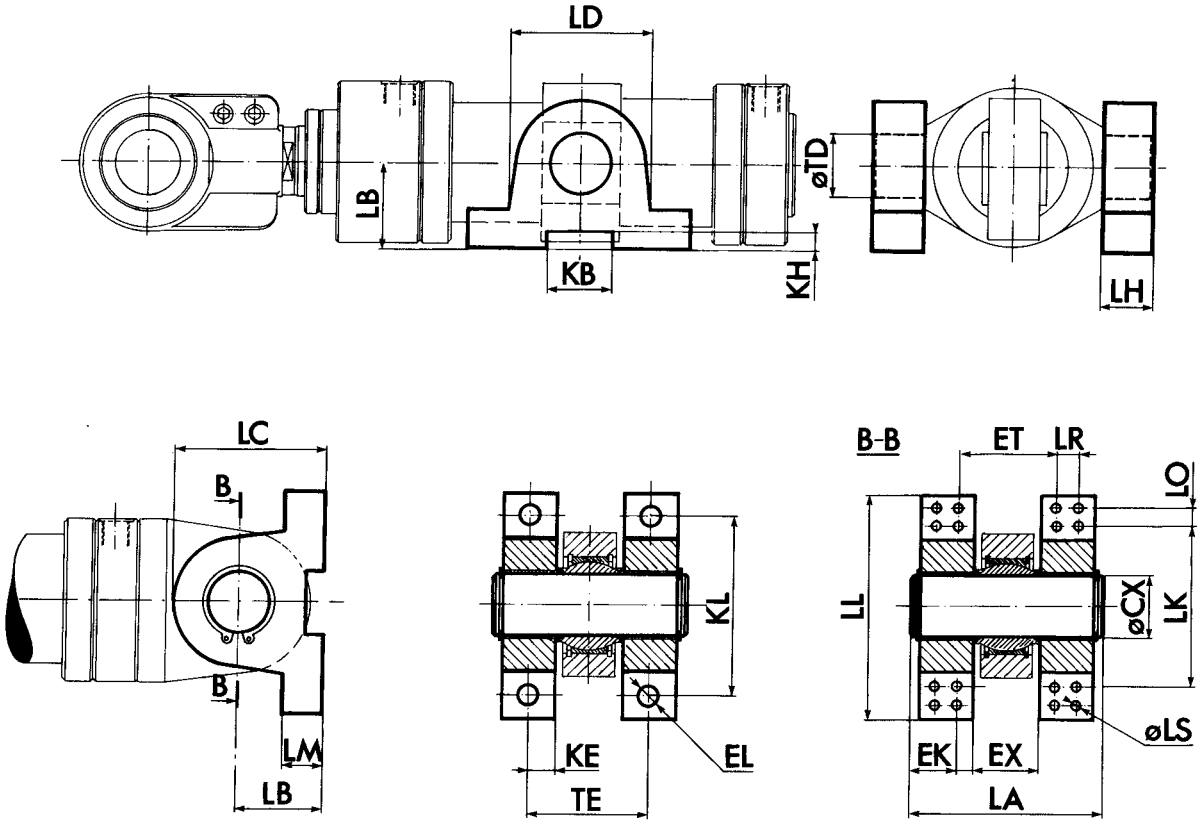

Cyl.D.	CX	EL	EK	ET	EX	LA	LB	LC	LD	LS	LH	LK
mm	mm	mm	mm	mm	mm	mm	mm	mm	mm	mm	mm	mm
toler.	H7/f8	H12	JS13	JS14	H12	max	JS12	max		H12	max	Js13
50	32	2x18	-	-	32	105	65	95	65	-	30	-
63	40	2x22	-	-	40	115	76	111	80	-	30	-
80	50	2x27	-	-	50	150	95	135	100	-	40	-
100	63	2x33	-	-	63	180	112	167	130	-	50	-
125	80	2x39	-	-	80	220	140	215	170	-	60	-
160	100	2x39	-	-	100	280	160	250	200	-	80	-
200	125	-	25	178	125	350	160	290	280	8x22	100	320
250	160	-	32	227	160	440	210	380	360	8x27	125	410
320	200	-	23	249	200	530	250	470	460	12x27	150	510
140	80	-	20	123	80	240	120	210	200	8x18	70	230
180	100	-	25	153	100	320	150	260	240	8x22	100	280
220	125	-	32	192	125	400	190	330	300	8x22	125	340
280	160	-	23	209	160	490	230	410	380	12x27	150	430

Bearing Brackets

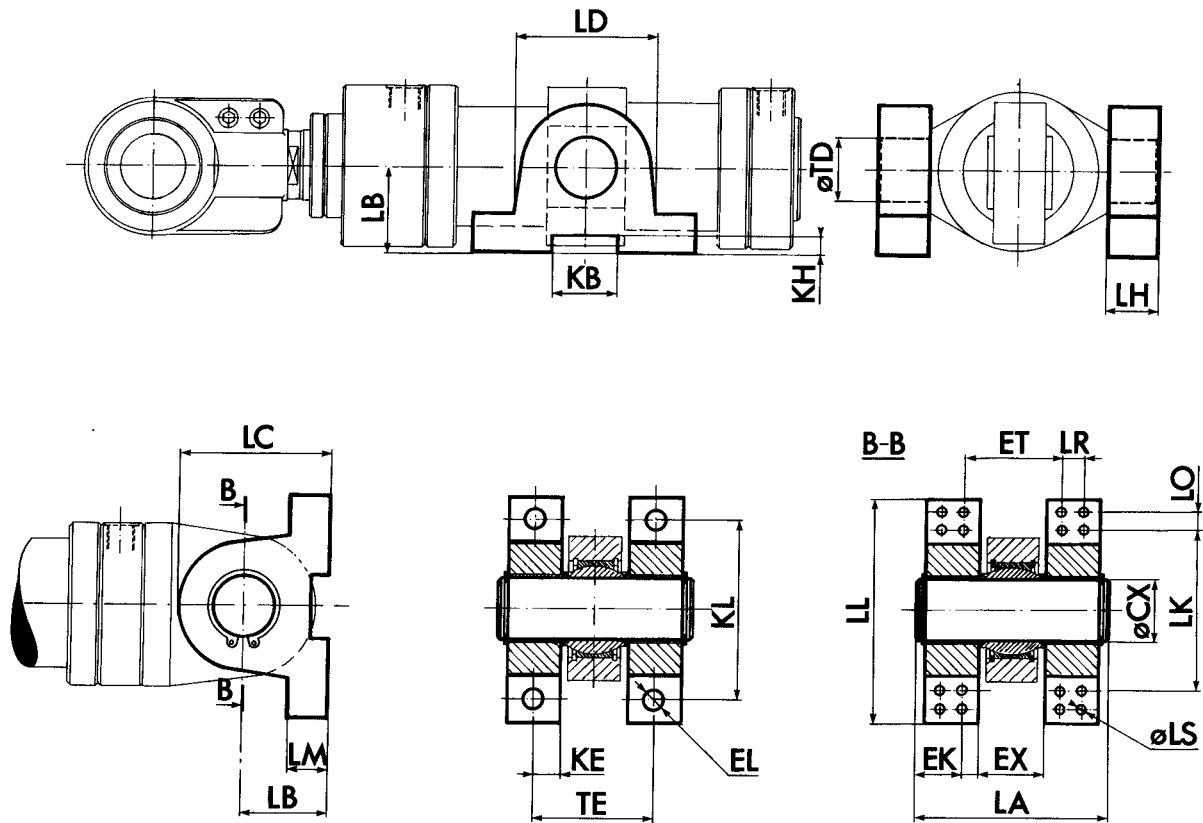

Cyl.D.	LL	LM	LO	LR	KB	KE	KH	KL	TD	TE	Vikt	
mm	mm	mm	mm	mm	mm	mm	mm	mm	mm	mm	p/par	m.axel
toler.			JS13	JS13	N9	JS13	+0,3	JS13	H7/f8	JS14	kg	kg
50	150	40	-	-	25	15	5,4	110	32	62	4,3	4,95
63	170	45	-	-	36	15	8,4	125	40	72	5,2	6,35
80	210	60	-	-	36	19	8,4	160	50	90	9,9	12,2
100	260	70	-	-	50	25	11,4	200	63	113	20,5	24,9
125	320	80	-	-	50	30	11,4	250	80	142	37,7	46,4
160	395	80	-	-	70	40	14,4	324	100	182	65,2	82,5
200	450	45	40	50	70	-	14,4	-	125	-	103,3	137,1
250	570	60	48	60	100	-	19,5	-	160	-	219,1	288,7
320	650	60	42	52	100	-	19,5	-	200	-	399,6	530,6
140	330	40	30	30	70	-	14,4	-	80	-	39,4	48,9
180	410	45	40	50	70	-	14,4	-	100	-	84,7	104,5
220	480	45	40	60	100	-	19,5	-	125	-	159,5	198,1
280	570	60	42	52	100	-	19,5	-	160	-	301,2	378,7

S-300 KGs/MP6s

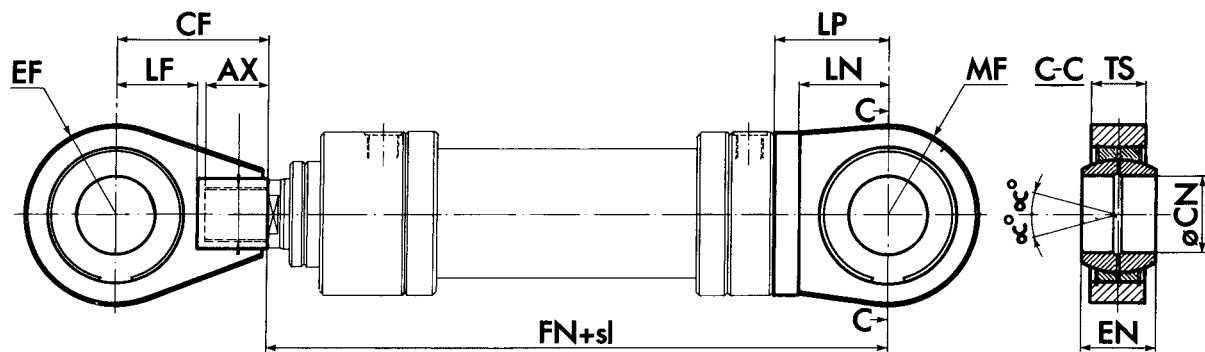

Cyl.dim.	AX	CF	CN M6	EF	EN	KK	LF	LN	LP	MF	TS	FN	CC	Weight	
														MP6S	KGS
mm	mm	mm	mm	mm	mm	mm	mm	mm	mm	mm	mm	mm		kg	kg
50	37	90	35	45	35	M 27x2	45	45	70	45	30	310	15	2,82	2,0
63	46	110	45	55	43	M 33x2	55	62	90	55	38	360	13	5,25	3,9
80	57	150	60	75	63	M 42x2	75	78	110	75	48	410	15	10,3	8,3
100	64	160	70	90	70	M 48x2	85	89	125	90	53	460	14	15,6	11,8
125	86	210	90	115	85	M 64x3	115	110	150	115	63	540	14	27,5	23,3
160	96	240	110	140	100	M 80x3	130	135	180	140	80	640	11	53,7	44,2
200	113	290	140	165	90	M 100x3	155	164	220	165	90	760	5	78,8	65,5
250	126	340	180	210	105	M 125x4	190	207	270	210	100	910	4	150,0	114,7
320	161	420	220	260	135	M 160x4	230	250	330	260	125	1080	5	261,5	211,2
140	86	210	100	120	85	M 64x3	115	115	155	120	70	570	12	32,8	28,0
180	96	260	120	155	115	M 80x3	150	155	200	155	90	690	16	66,0	56,3
220	113	310	160	180	105	M 100x3	175	175	230	180	100	790	6	102,5	82,1
280	126	360	200	225	130	M 125x4	210	215	280	225	125	930	4	192,1	152,5

Bearing Brackets Type S

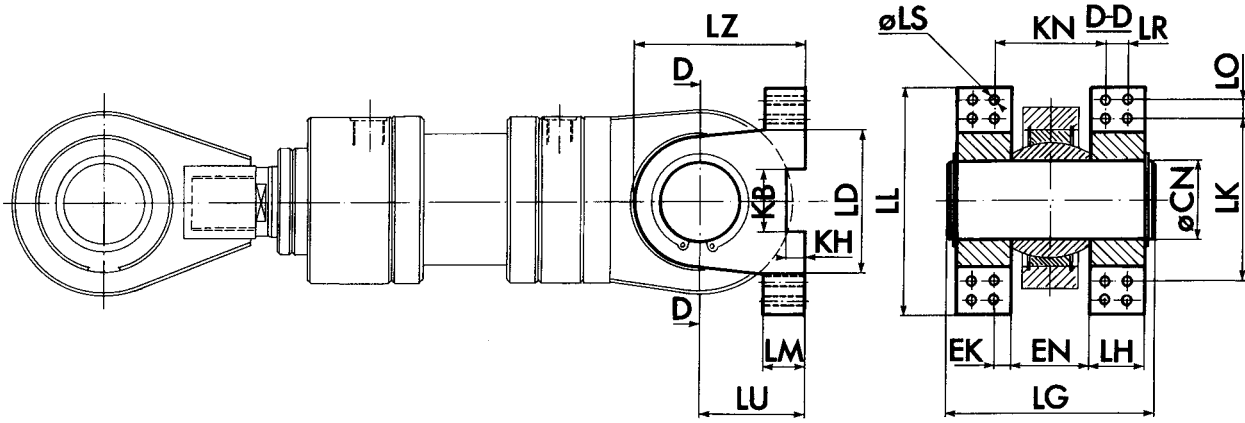

Cyl.dim.	CN M6/f8	EN	EK	KB	KH	KN	LD	LG	LH	LK	LL	LM	LO	LR	nxLS H13	LU	LZ	Weight
mm	mm	mm	mm	mm	mm	mm	mm	mm	mm	mm	mm	mm	mm	mm	mm	mm	mm	
50	35	35	8,5	25	5,4	54	70	110	30	86	130	30	13	13	8x6,5	65	95	3,86
63	45	43	8,5	36	8,4	63	90	120	30	106	150	30	13	13	8x6,5	76	115	5,95
80	60	63	11	36	8,4	88	110	160	40	130	190	30	18	18	8x8,5	95	145	12,6
100	70	70	13	50	11,4	99	130	190	50	155	230	35	24	24	8x11	112	170	21,9
125	90	85	15	50	11,4	118	180	225	60	210	300	40	30	30	8x13	140	220	45,2
160	110	100	20	70	14,4	143	220	285	80	250	350	40	30	40	8x18	160	265	86,4
200	140	90	25	70	14,4	143	280	315	100	320	450	45	40	50	8x22	180	320	161,2
250	180	105	32	100	19,5	172	360	380	125	410	570	60	48	60	8x27	230	410	323,9
320	220	135	23	100	19,5	184	460	465	150	510	680	60	42	52	12x27	280	510	599
140	100	85	20	70	14,4	128	200	245	70	230	330	40	30	30	8x18	135	235	61,2
180	120	115	25	70	14,4	168	240	340	100	280	410	45	40	50	8x22	170	290	129,2
220	160	105	32	100	19,5	172	300	380	125	340	470	45	40	60	8x22	200	350	235,9
280	200	130	23	100	19,5	179	380	455	150	430	600	60	42	52	12x27	250	440	447,6



Teknikergatan 5
SE-781 70 Borlänge
Sweden

Tel. +46 (0)243-820 75
Fax +46(0)243-102 82
www.arcos.se